

Simple Transistorized Ignition Retrofit for Old Cars

This is a Transistorized Ignition circuit to replace the OEM standard (non-electronic) ignition using the original ignition coil and breaker points with modifications so minimal that a flip of a switch is enough to restore the original ignition circuit, thus permitting electronic ignition to be compared with standard ignition instantly at any time. *No access is needed to the ignition coil's (+) terminal.* The circuit is designed to relieve the breaker points of electric erosion caused by heavy current, thereby rendering point adjustment unnecessary after the first 5000 mi. until over 50,000 mi., so that ignition performance does not degrade below its optimum as time passes. I used this circuit for five years, 1969-73, in a car driven across the continent three times in all weather, freezing winters, baking summers, and a flood. Only Capacitive Discharge is better.

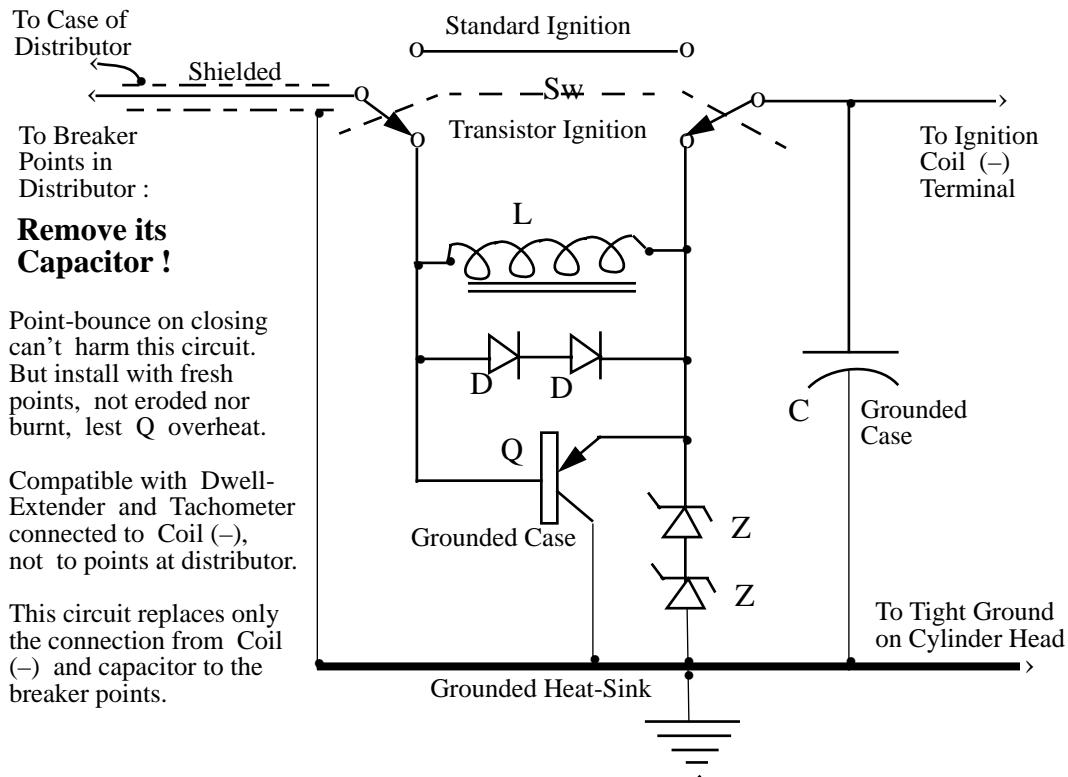

Components:

- Sw Rugged DPDT switch, 10 A. 250 V., waterproof.
- L 2.5 mh., ferrite core, 10 to 15 Ω .
- D (Two) Si. diode, $\geq 1\text{A.}$, $\geq 50\text{ V.}$; 1N4000
- C 600 V., hermetically sealed, mylar or paper, foil or metallized, with same capacitance as capacitor removed from across breaker points in distributor.
- Q Ge. PNP Transistor, $I_C = 10\text{ A.}$, $V_{CEO} = 320\text{ V.}$; Motorola HEP 235
- Z (Two) Zener diode, 100 to 120 V., 5 W.; Motorola HEP Z2547

Tight grounds and clean points are crucial lest Q be destroyed. Under normal conditions the circuit dissipates less than 3W.; still, Q and Zs should be clamped to a heat-sink in a waterproof box mounted low in the engine compartment away from heat sources and vibration. Only failure of switch Sw or capacitor C can disable both ignition modes. Install with fresh points; since point erosion is almost eliminated you may safely increase point dwell by up to 20% and advance spark timing by 2° to retard rubbing-block wear and improve high-speed performance. And widening spark-plug gaps by about 20% will improve low-speed running and starting.