

## PTC Thermistors, For Temperature Protection

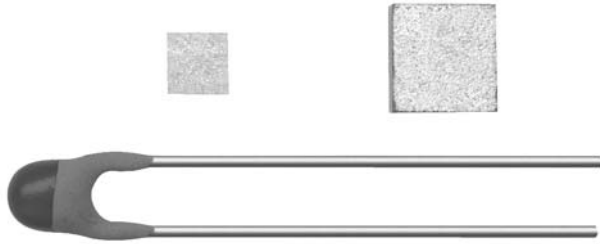

### FEATURES

- Well-defined protection temperature levels
- Very fast reaction time
- Accurate resistance for ease of circuit design
- Excellent long term behavior
- Wide range of protection temperatures
- No need to reset supply after overtemperature switch
- Small size and rugged
- Coated leaded and naked devices available.

### APPLICATIONS

- Industrial electronics
- Power supplies
- Electronic data processing
- Motor protection.

### DESCRIPTION

These directly heated thermistors have a positive temperature coefficient and are primarily intended for sensing.

### QUICK REFERENCE DATA

PARAMETER	VALUE	UNIT
Maximum resistance at 25 °C	120	Ω
Minimum resistance at (T <sub>n</sub> + 15) °C	4000	Ω
Maximum (DC) voltage	30	V
Temperature range	-20 to (T <sub>n</sub> + 15)	°C
Weight:		
91002 to 91014	≈0.013	g
91072 to 91087	≈0.003	g
91102 to 91114	≈0.08	g
91152 to 91164	≈0.09	g
Climatic category	25/125/56	

### NOMINAL WORKING TEMPERATURES AND ORDERING INFORMATION

NOMINAL WORKING TEMPERATURE				TYPE/CATALOG NUMBER 2322 ... ..				
T <sub>n</sub> (°C)	RESISTANCE from -20 °C to T <sub>n</sub> -20 °C (Ω)	RESISTANCE at T <sub>n</sub> -5 °C (Ω)	RESISTANCE at T <sub>n</sub> +5 °C (kΩ)	NAKED CHIP <sup>(1)</sup>		LEADED DEVICE		
				1.0 × 1.0 (mm)	1.7 × 1.7 (mm)	NORMAL LEADS	LONG LEADS	COLOR CODE
				671 .....	671 .....	671 .....	671 .....	
70	30 to 250	50 to 570	0.570 to 50	91072	91002	91102	91152	black
80	30 to 250	50 to 550	1.33 to 50	91073 <sup>(2)</sup>	91003	91103	91153	brown
90	30 to 250	50 to 550	1.33 to 50	91074 <sup>(2)</sup>	91004	91104	91154	red
100	30 to 250	50 to 550	1.33 to 50	91075 <sup>(2)</sup>	91005	91105	91155	orange
110	30 to 250	50 to 550	1.33 to 50	91076	91006	91106	91156	yellow
120	30 to 250	50 to 550	1.33 to 50	91077	91007	91107	91157	green
125	30 to 250	50 to 550	1.33 to 50	91078	–	–	–	–
130	30 to 250	50 to 550	1.33 to 50	91079	91009	91109	91159	blue
135	30 to 250	50 to 550	1.33 to 50	91081	–	–	–	–
140	30 to 250	50 to 550	1.33 to 50	91082	91012	91112	91162	violet
145	30 to 250	50 to 550	1.33 to 50	91083	–	–	–	–
150	30 to 250	50 to 550	1.33 to 50	91084	91014	91114	91164	grey
155	30 to 250	50 to 550	1.33 to 50	91085	–	–	–	–
160	30 to 250	50 to 550	1.33 to 50	91086	91016	–	–	–
170	30 to 250	50 to 550	1.33 to 50	91087	91017	–	–	–

#### Notes

1. Naked chips are packed in a hermetically-sealed alu-plastic bag.
2. Resistance at T<sub>n</sub> +5 °C = 0.570 to 50 kΩ.

<b>ELECTRICAL CHARACTERISTICS</b>	
PARAMETER	VALUES
Maximum resistance at 25 °C	120 Ω
Maximum resistance at (T <sub>n</sub> - 5) °C	see Nominal Working Temperatures and Ordering Information table
Minimum resistance at (T <sub>n</sub> + 15) °C	4000 Ω
Minimum resistance at (T <sub>n</sub> + 5) °C	see Nominal Working Temperatures and Ordering Information table
Maximum voltage	30 V (AC or DC)

**DIMENSIONS** in millimeters

<b>PACKAGING QUANTITIES AND CATALOG NUMBERS</b>		
PACKAGING		CATALOG NUMBERS
SPQ	PQ	2322 ... ..
5000	20000	671 91002 to 671 91014
5000	20000	671 91072 to 671 91087
500	5000	671 91102 to 671 91114
500	5000	671 91152 to 671 91164

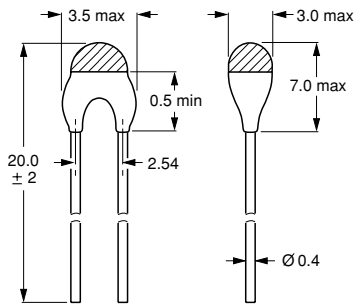
**COMPONENT OUTLINES**

Component outline for 91102 to 91114.

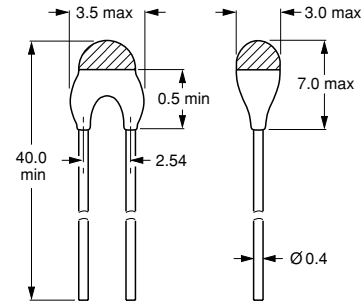

Component outline for 91152 to 91164.

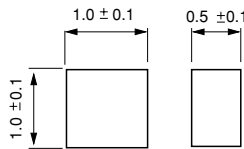

Component outline for 91071 to 91087.

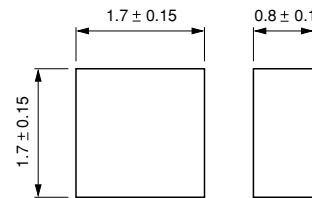

Component outline for 91002 to 91017.

For clamping, reflow or hand soldering. Not intended for either wave or ultrasonic soldering and not for spot welding.  
 All standard solder alloys with low activated halogene-free fluxes are acceptable, for example: 62Sn/36Pb/2Ag.

**APPLICATION SPECIFIC DATA**

Negative Temperature Coefficient (NTC) thermistors are well known for temperature sensing. What is not well known, however, is that Positive Temperature Coefficient (PTC) thermistors can be used for thermal protection. Although their operating principles are similar, the applications are very different; whereas NTC thermistors sense and measure temperature over a defined range, PTC thermistors switch at one particular temperature.

Just like thermostats they protect such equipment and components as motors, transformers, power transistors and thyristors against overtemperature. A PTC thermistor is less expensive than a thermostat, and its switch temperature can be more accurately specified. It is also smaller and easier to design-in to electronic circuitry.

So how does it work? The PTC thermistor is mounted in thermal contact with the equipment to be protected, and connected into the bridge arm of a comparator circuit, such as shown in Fig.1. At normal temperature, the PTC thermistor resistance ( $R_p$ ) is lower than  $R_s$  (see Fig.2), so the comparator's output voltage  $V_o$  will be low. If an equipment overtemperature occurs, the PTC thermistor will quickly heat up to its trigger or nominal reference temperature  $T_n$ , whereupon its resistance will increase to a value much higher than  $R_s$ , causing  $V_o$  to switch to a high level sufficient to activate an alarm, relay or power shutdown circuit.

**APPLICATION EXAMPLES**

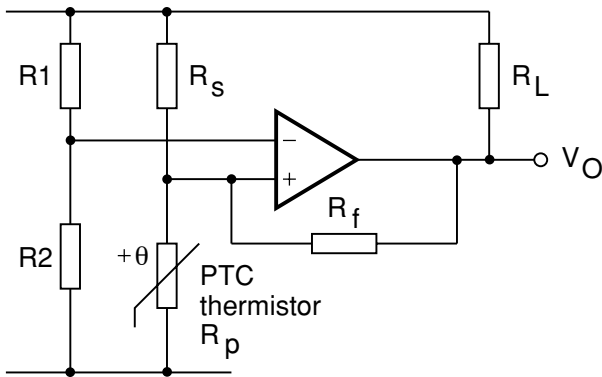

Fig.1 .Typical comparator circuit.

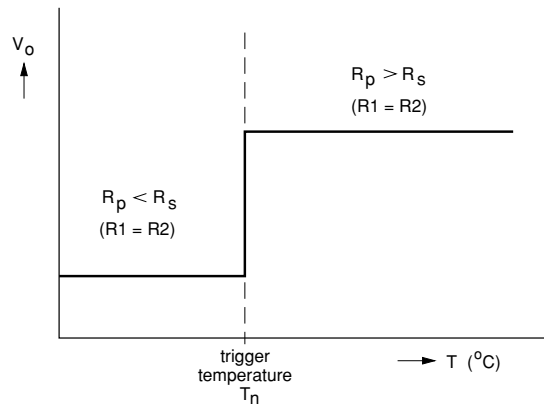
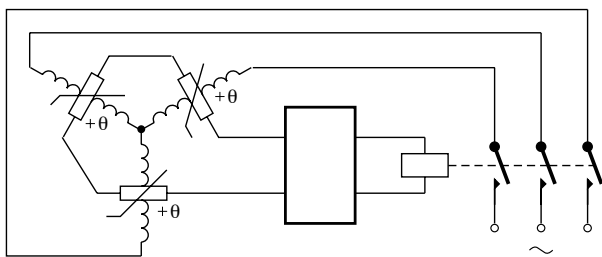
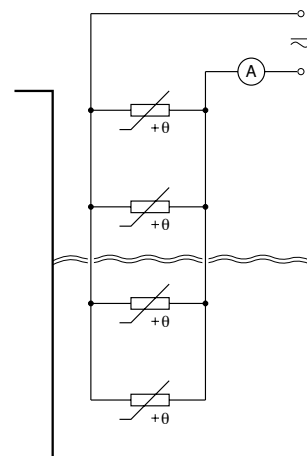

Fig.2 Typical switch characteristic.



As soon as one or more of the windings becomes too hot, the motor is switched off.

Fig.3 Temperature protection of electric motors



The PTC thermistors located above the fluid level will be heated to a temperature greater than  $T_n$ . When immersed they are cooled such that their resistance value is reduced.

Fig.4 Liquid-level indication.

**TYPICAL RESISTANCE/TEMPERATURE CHARACTERISTIC FOR** 2322 671 91052/002/102, 91053/003/103 and 91054/004/104.

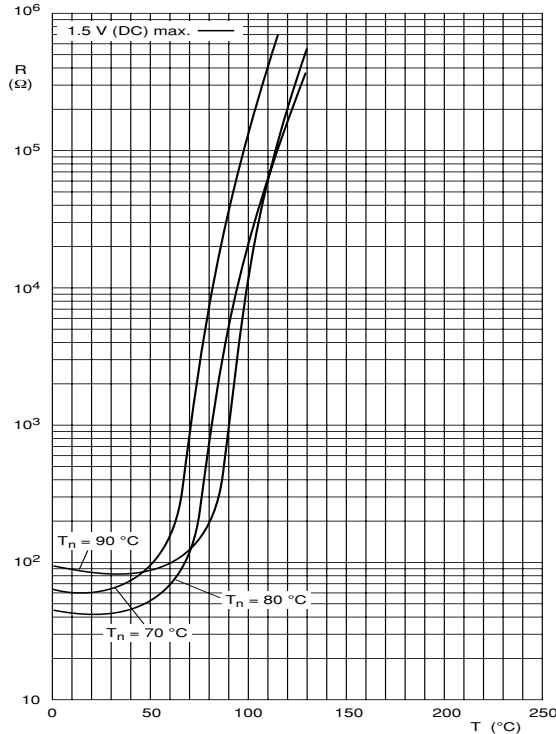

**TYPICAL RESISTANCE/TEMPERATURE CHARACTERISTIC FOR** 2322 671 91055/005/105, 91056/006/106 and 91057/007/107.

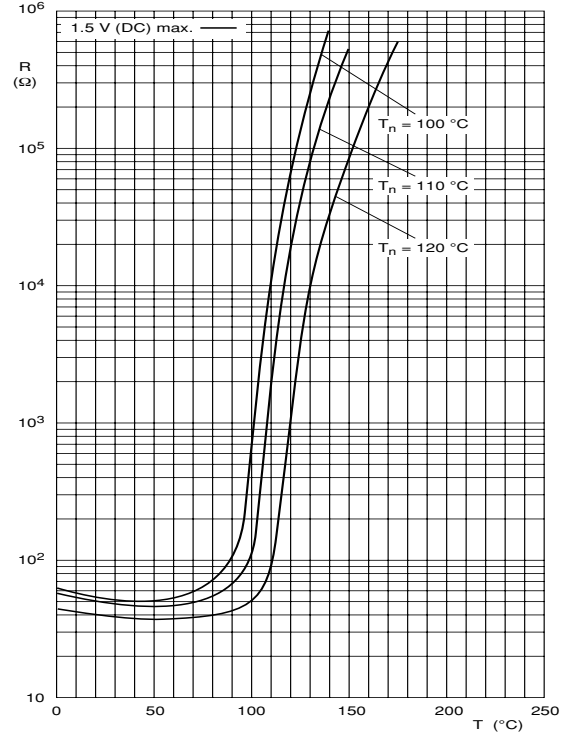

**TYPICAL RESISTANCE/TEMPERATURE CHARACTERISTIC FOR** 2322 671 91058, 91059/009/109 and 91061.

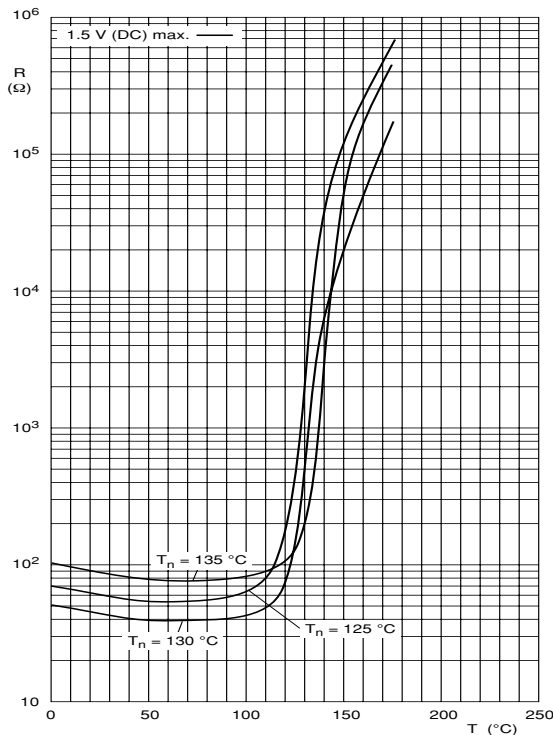

**TYPICAL RESISTANCE/TEMPERATURE CHARACTERISTIC FOR** 2322 671 91062/012/112, 91063 and 91064/014/114.

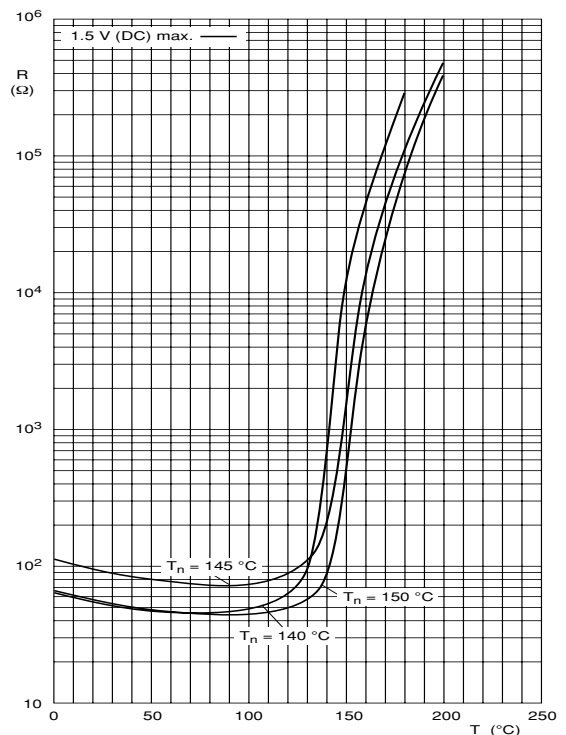



**TYPICAL RESISTANCE/TEMPERATURE CHARACTERISTIC FOR 2322 671 91065, 91066 and 91067.**

